

# SESAR Master Plan

EBACE

Geneva, 20 May 2008

Bernard Miaillier

Head of SESAR & ATM Strategy

# SESAR: Committing to Make Future Happen

## European Challenges:

- Traffic forecast to double by 2025, new air vehicles
- Growth must come with significant performance improvement
- Issues: ATC pushed to its limits; obsolescent technologies; airspace fragmentation

## A new ATM System is required

### Needs:

- Turn off fragmented approach
- **Accelerate** evolution in response to challenges
- **Synchronise** plans and actions
  - from research to operations
  - airborne and ground deployments

### SESAR

- Technical/operational change, supported by Single European Sky legislation
- **Direct involvement of aviation industry in all phases**
- Address European needs and Global interoperability



# SESAR Cohesive Programme for Stepwise Implementation

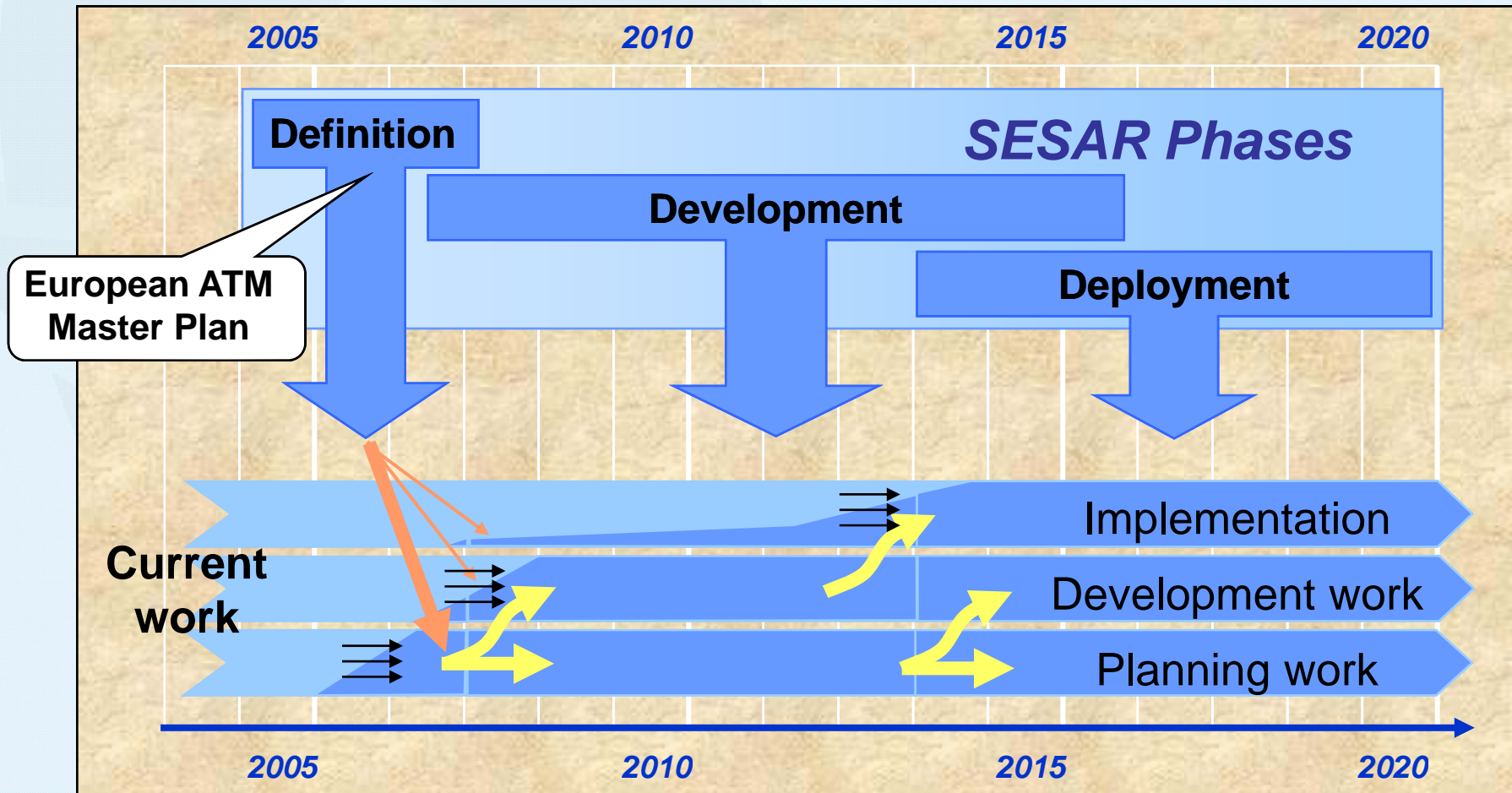

# Design for Growth – Deploy When & Where Needed

*Performance targets derived from  
needs of society & airspace users*

*Progressive deployment,  
when/where needed*

2020 targets:

- ✓ Capacity: + 73% overall
- ✓ Safety: improvement factor 3
- ✓ Environment: max. contribution
- ✓ Costs to airspace users: - 50%

Design Goals for scalable future  
capability:

- Capacity: handle 3 times traffic
- Safety: factor 10
- Environment: - 10% effects / flight
- Costs to airspace users: - 50%

Also addressed:  
Security, Efficiency, Flexibility,  
Predictability, Global Interoperability,  
Access, Equity, Participation

(Reference: 2005)

# SESAR Concept of Operations is a Paradigm Shift for ATC

## Past

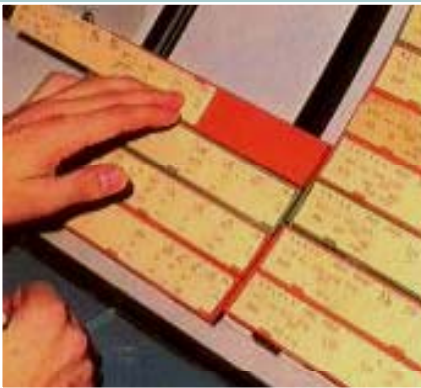

### Procedural Control

*Estimate the current and planned a/c positions*

## Today



### Radar Control

*Know the current and estimate planned a/c positions*

## Future

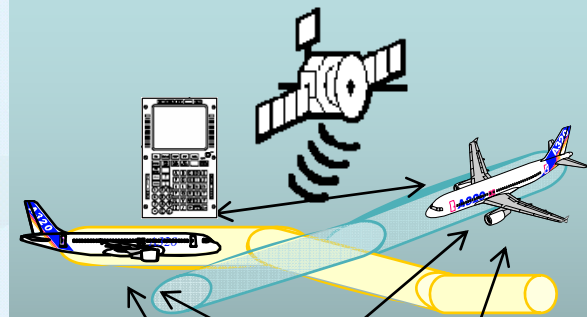

### Trajectory Management

*Know & share the current & planned a/c positions*

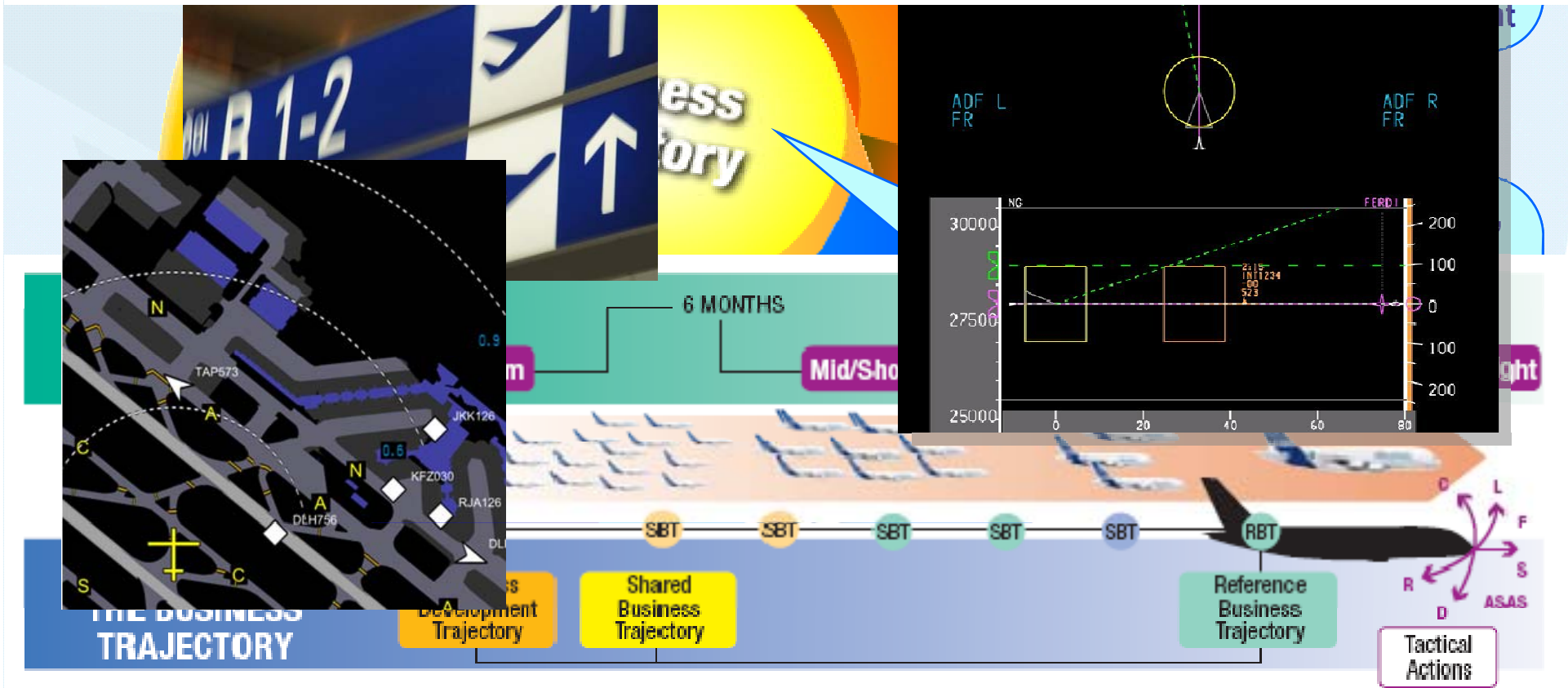
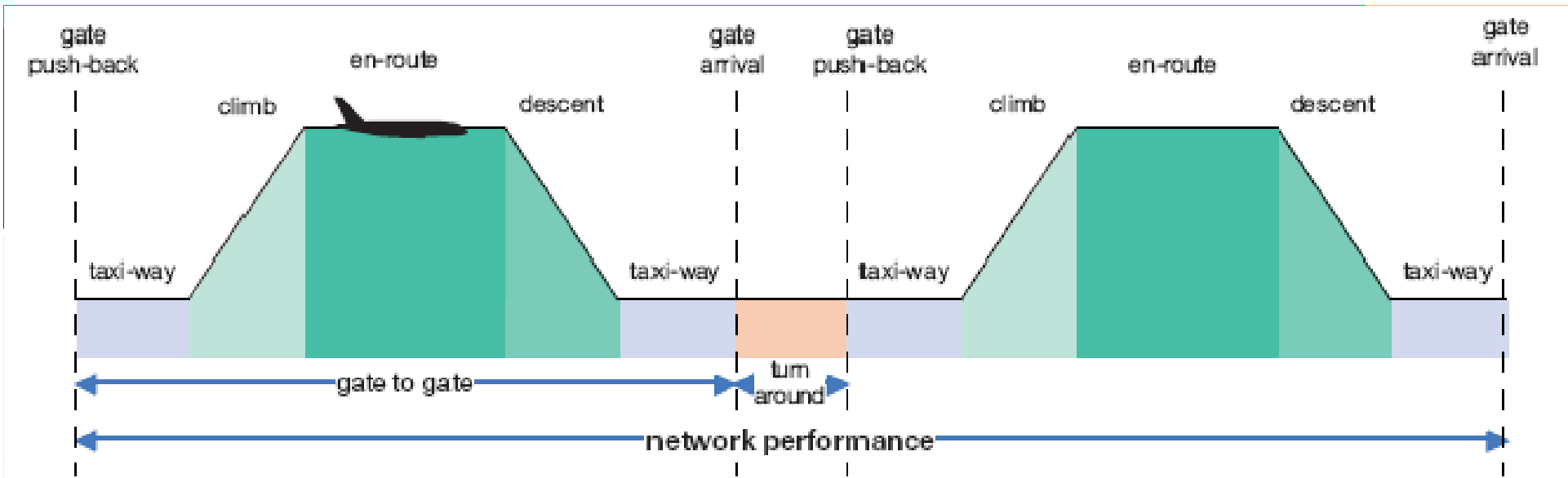

# Enablers of the Operational Change

## Technical

- Common system architecture, service oriented
  - New CNS technologies
  - E.g. satellite navigation, new data link, more flexible avionics

## Managerial & Institutional

- Business case to support decision making
- Change management process
  - including human aspects & social dialogue
- Timely standardisation & rule making
- Effective commitment of all actors
- Financial instruments

# ATM Deployment Sequence Based on Capability & Service Levels

Implementation based on **ATM Capability Level**: sets of functional evolutions for Aircraft, ATC Centres, Airports, Network Management

**IP1**

**IP2**

**IP3**

- Implementing available technologies & Best practices e.g. DMEA, Link
- ...

Ready for implementation

ACL #0

2008

- Curved approaches
- AMAN/DMAN integration
- ATSAW
- ...

Ready for implementation

ACL #1

2013

- ASPA-S&M
- UDPP
- Improved LVO
- 3D-PTC on predefined routes
- 2D-PTC on preferred routes
- ...

Ready for implementation

ACL #2

2017

- 3 Airspace categories
- Free routing from TOC -> ToD
- Revision of RBT/DL
- Multiple CTB
- ...

Ready for implementation

ACL #3

2020

- 2 Airspace categories
- ASEP C&P
- 3D-PTC on preferred routes
- SVS
- ...

Ready for implementation

ACL #4

2025

- ASAS-SSEP
- 4D-PTC
- Self adjustment on WV
- ...

Ready for implementation

ACL #5

**ATM Service Level** delivered to the Airspace User: results from the lowest ATM Capability Level of the different interacting Stakeholders

# Master Plan Overview

year 2010 2015 2020 2025

SL

0

1

2

3

4

5

R&D  
Deployment  
Operations

CDM procedures with airports  
CDA/RNP approaches  
Increased traffic awareness

NOP Interface/CDM procedures with all actors  
Support SBT to RBT process  
Expanded data link services  
Aircraft spacing/4Dtrajectory containment

Free routing flight planning  
Precision 4D trajectory management  
Improved precision landing  
ASAS separation

High Integrity Management  
Increased data link capability  
Increased ADS-B capability ASAS separation  
Air to Air data exchange

# ATM Master Plan

- Provide different views:

- Roadmap for Operational Evolutions
- Plans viewed from Stakeholders perspectives
- Roadmap for “transversal” aspects (regulation, safety, environment)

WARNING: Data contained within the Gantt chart is for demonstration purposes only and should not currently be used to support SESAR task activities. Please see the relevant reports in the SESAR eRoom or ACIG extranet site for officially approved data.

- Address full life cycle:

- R&D, Deployment, Innovative research

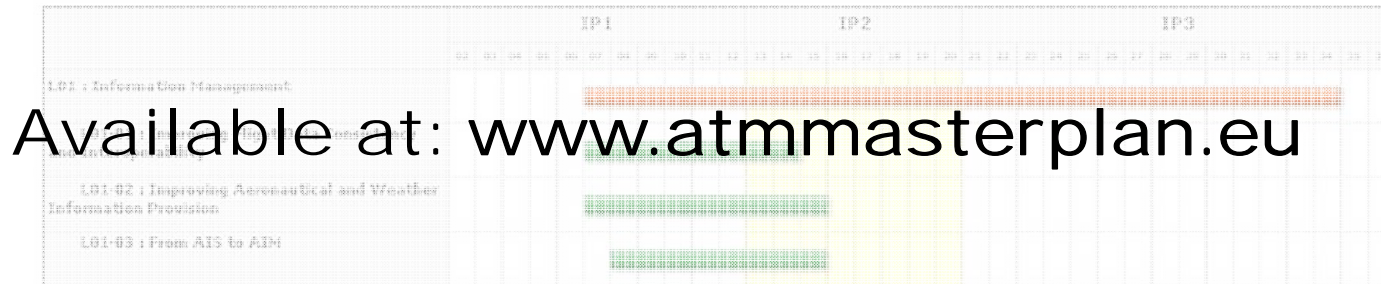

Available at: [www.atmmasterplan.eu](http://www.atmmasterplan.eu)

# Specific Implications/Opportunities for Business Aviation - 1

## *General*

BA, like other airspace users, will benefit from

- Performance and service level improvements enabled by enhanced ATM capability (air, ground & airport)
  - Increased airspace capacity with minimal segregation
  - Reduced unit cost
  - Quest for global interoperability
- 
- Individual operational benefits easier to achieve when not entangled in interactions with dense traffic or implied in network effects
- 
- SESAR cannot solve structural airport infrastructure congestion
    - Situation at those airports not to change significantly

# Specific Implications/Opportunities for Business Aviation - 2

- Safe, capacitive access to low airspace and secondary airports
  - Through precision approach, electronic visibility of all traffic, remote tower
  - No proliferation of new technologies, but ability to serve both a wide European territory & the high requirements of main airports & dense airspace
- Simplification of airspace structure for BA safety
- Flexibility to accommodate unplanned flights or events
  - but when this has a network effect, the individual optimum cannot be achieved
- Early implementation & use of new technologies in low density airspace (high FL; lower airspace), e.g. ASAS self-separation
  - BA an interesting partner for live trials and to generate early individual benefits

# Evolution is needed – Technology is a Means

- To accommodate safely and cost-effectively larger volumes of faster a/c with a larger flight envelop implies
  - Reduce uncertainties (position, navigation),
  - Know and anticipate on flight environment, incl. other interacting traffic (communications, surveillance, AIS, MET)
- We fully recognise that
  - Affordability has not the same meaning to all users
  - Light aircraft need light avionics
  - Business case is a hard issue
- But in turn we stress that
  - The least performing may be a handicap to the others

# Work Programme WBS

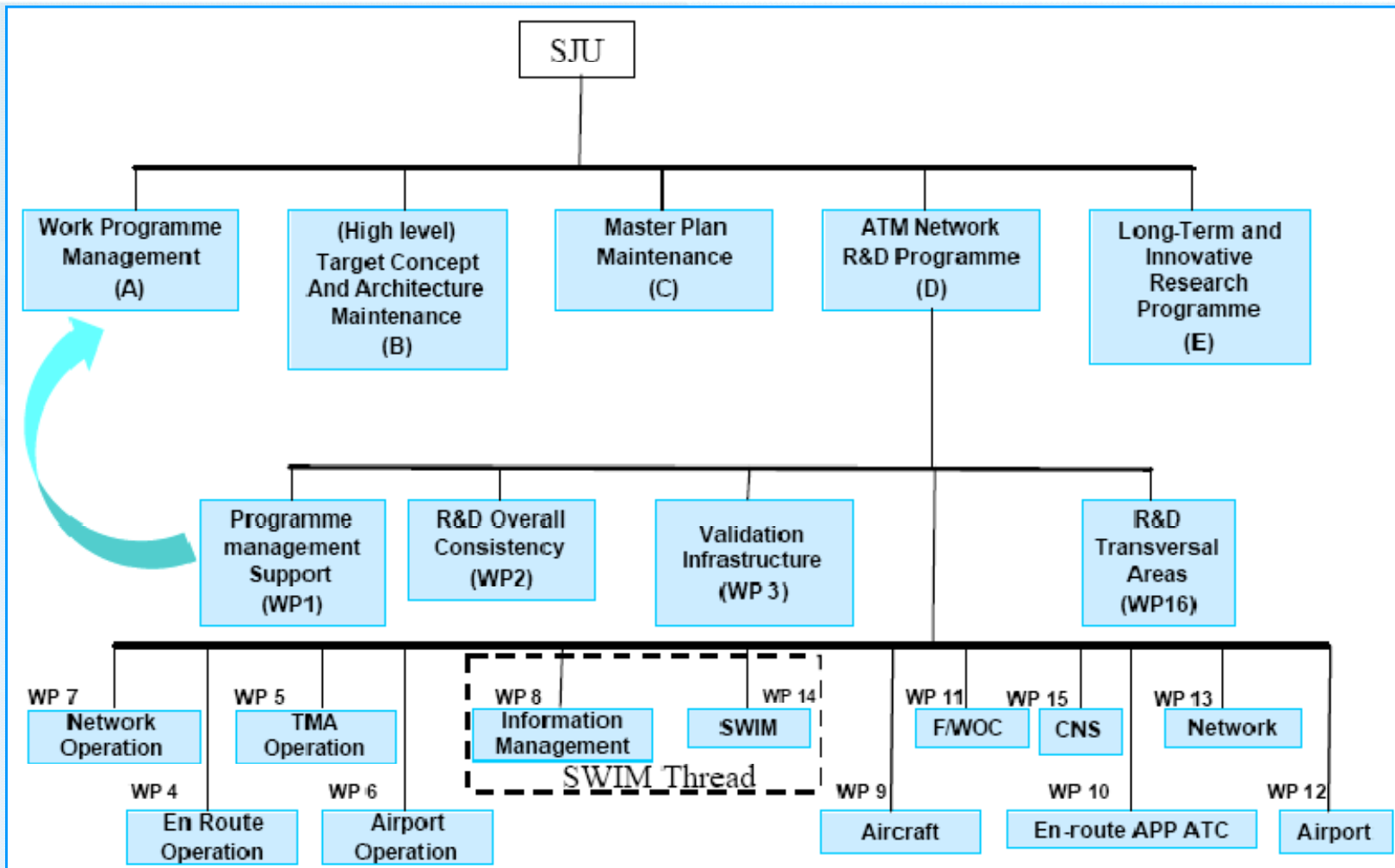

# Conclusion



- SESAR brings a new dimension to European ATM and to regional integration efforts
  - It is for all users
  - Interoperability is a priority
- A Key success factor for an efficient ATM Network:
  - All stakeholders' commitment to the ATM Master Plan